

---

# AQT-56

---

## POWERFLO SERIES

---



## TABLE OF CONTENTS

Products Checking List	3
General Residential Installation Check List	4
AQT-56ST Softener Timer Control Valve Start-up Procedures	5
AQT-56FT Filter Timer Control Valve Start-up Procedures	6
AQT-56SM Meter Control Valve Start-up Procedures	7
Water Conditioner Flow Diagrams	8
AQT-56ST Softener Time Control Valve Drive Assembly	12
Time Control Valve Drive Assembly Parts List	13
AQT-56SM Softener Meter Control Valve Drive Assembly	14
Meter Control Valve Drive Assembly Parts List	15
Control Valve Assembly	16
Control Valve Assembly Parts List	17
Meter Assembly and Parts list	18
Notes	19

**Products series check**

- AQT-56ST (Softener timer)       AQT-56SM (Softener timer)       AQT-56FT (Filter timer)
- AQT-56FM (Filter meter)
- Other Model: \_\_\_\_\_

**Electric motor**

- 110V/60Hz       220V/50Hz       220V/60Hz
- 24V/60Hz 220V/60Hz       Other Model: \_\_\_\_\_

**Flow Meter**

- 2100 Gallon/Plastic (8T)       120v/60Hz       220v/60z

**Yoke**

- 3/4" NPT Plastic       1" NPT plastic

**Injector nozzle/throat**

- #0 Red       #1 Natural       #2 Blue
- #3 Yellow

**B.L.F.C**

- 0.125 GPM       0.25 GPM       0.5 GPM

**D.L.F.C**

- 1.2 GPM       1.5 GPM       2.0 GPM
- 2.4 GPM       3.0 GPM       3.5 GPM
- 4.0 GPM       5.0 GPM

**Piston & Valve Position Dial**

- Standard       LW (Low Water)       Filter (for Filter Valve Only)

**Power Cord & Plug**

- CN       US       UK
- EU       JP       Other: \_\_\_\_\_

Input Power: \_\_\_\_\_

Parts chosen will be installed into the valve as default.

## General Residential

### Installation Check List

Water Pressure	Minimum 25 PSI
Electrical Supply	Uninterrupted AC. Check voltage compatibility
Existing	Free of any deposits or build-ups inside pipes
Softener	Locate close to drain and connect according to plumbing codes
Bypass Valves	Always provide for bypass valve if unit is not equipped with one

CAUTION	
	Do not exceed 120 PSI water pressure
	Do not exceed 100°F water temperature
	Do not subject unit to freezing conditions

### General Valve Installation Procedure

Note: Install the water softener with the inlet, outlet and drain connections made according to manufacturer's recommendations and to meet applicable plumbing codes.

1. Locate the softener tank close to a drain where you wish to install the unit. Note: Be sure the tank is level and on a firm base.
2. Perform all plumbing according to local plumbing codes.
  - Use a 1/2" minimum pipe size for the drain.
  - Use a 3/4" drain line for backwash flow rates that exceed 7 gpm or length that exceeds 20' (6 m).
3. Cut the 1" distributor tube (1.050 O.D.) flush with top of each tank.  
Note: Only use silicone lubricant.
4. Lubricate the distributor O-ring seal and tank O-ring seal. Screw the valve on to the tank.
5. Use only Teflon tape on the drain fitting. Solder joints near the valve must be done before connecting any piping to the valve. Always leave at least 6" (152 mm) between the valve and solder joints when soldering pipes that are connected to the valve. Failure to do this could cause damage to the valve.
6. Be sure the floor under the brine tank is clean and level.
7. Add water until there is approximately 1" (25 mm) of water above the grid plate. If a grid is not utilized, fill to the top of the air check in the brine tank. Do not add salt to the brine tank at this time.
8. On units with a bypass, place in Bypass position.
  - Turn on the main water supply.
  - Open a cold soft water tap nearby and let water run a few minutes or until the system is free of foreign material (usually solder) resulting from the installation. Close the water tap when water runs clean.
9. Place the bypass in the In Service position and let water flow into the mineral tank. When water flow stops, slowly open a cold water tap nearby and let water run until air is purged from the unit. Then close tap.
10. Plug the valve into an approved power source

# MODEL AQT-56ST

## Installation & Start-Up Procedure

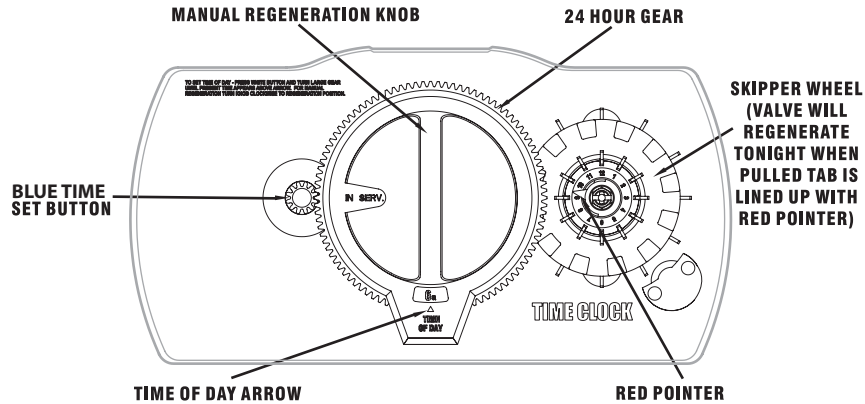

### Model: AQT-56ST

1. Manually index the softener control into the In Service position and let water flow into the resin tank. When the water flow stops, open a softened water tap until all air is released from the lines. Then close tap.  
Note: Manually dial the various regeneration positions by turning the knob on the front of the control until the indicator shows that the softener is in the desired position.
2. Manually index the control to the Backwash position and allow water to flow at the drain for 3 or 4 minutes.
3. Remove back cover plate.
4. Make sure that the salt dosage is set as recommended by the manufacturer. If necessary, set salt according to the setting instruction sheet. Manually index the control to the Brine Fill position and allow the brine tank to fill to the top of the air check.
5. Manually index the control to the Brine Draw position and allow the control to draw water from the brine tank until it stops.
6. Plug in the electrical cord and look in the sight hole in the back of the motor to see that it is running. Set the days that regeneration is to occur by sliding tabs on skipper wheel upward .
  - Each tab is one day.
  - Finger at red pointer is tonight.
  - Moving clockwise from red pointer, pull or push fingers to obtain the desired regeneration schedule.
7. Manually advance the control to the beginning of the Brine Fill position and allow the control to return to the In Service position automatically.
8. Fill the brine tank with salt.
9. Replace back cover on the control.
10. Make sure that any bypass valving is left in the normal In Service position.

### Softener Timer Regeneration Reference Chart

Softeners	Hardness PPM (GPC)	17-85	86-170	171-256	257-342	343-427	428-513	514-598	599-684	685-769	770-855	856-940	941-1026	1027-1111	1112-1197	1198-1282	1283-1368
		(1-5)	(6-10)	(11-15)	(16-20)	(21-25)	(26-30)	(31-35)	(36-40)	(41-45)	(46-50)	(51-55)	(56-60)	(61-65)	(66-70)	(71-75)	(76-80)
No. Of Persons		Calendar Clock Regenerations Frequency - No. Of Tab Pull Upwards															
2	1	1	1	1	1	2	2	2	2	2	3	3	3	3	3	3	3
3	1	1	2	2	3	3	3	3	3	3	4	4	4	4	4	4	4
4	1	2	2	2	3	3	3	4	4	4	6	6	6	6	6	6	6
5	2	2	3	3	4	4	4	4	6	6	6	6	6	12	12	12	12
6	2	2	3	3	4	4	4	6	6	6	6	6	12	12	12	12	12
7	2	3	3	4	4	6	6	6	6	12	12	12	12	12	12	12	12
8	2	3	3	4	6	6	6	6	6	12	12	12	12	12	12	12	12
9	3	3	4	4	6	6	12	12	12	12	12	12	12	12	12	12	12
10	3	4	4	6	6	12	12	12	12	12	12	12	12	12	12	12	12

# AQT-56FT Meter Filter Valve

## Start-up Procedures

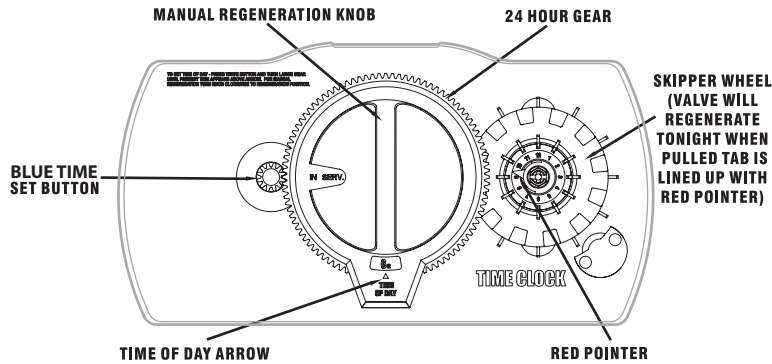

**Model: AQT-56FT**

### Before Plugging in the Unit

1. Open a treated water tap down stream of the filter.
2. Manually index the filter to the In Service position and allow the mineral tank to fill by slowly opening the main water supply valve. Any bypass should be in the In Service position.  
Note: The water flowing from the downstream tap is cloudy and/or contains media fines as well as air. Allow the water to run until it appears clean and free of air.
3. When a steady clean flow appears at the tap, close the tap and the main water supply valve and allow the filter media bed to settle for 15–20 minutes.
4. Manually index the filter to the Backwash position.
5. To prevent a sudden surge of water and air, partially open the main water supply valve so that the flow at the drain of the filter is approximately 1 gpm (3.7 Lpm). The water at the drain is cloudy again and/or contains media fines as well as air. Allow water to flow at the drain until it appears clean and free of air.
6. Continue to open the water supply valve until it is completely open. Allow water to flow at the drain until all media fines are washed out of the filter.
7. Manually index the filter to the In Service position, and again open the downstream tap. Check to be sure that the water flows clear. If necessary, allow water to flow until all media fines are gone. If the tap is equipped with an aerator check that is not plugged with media fines and pipe scale.
8. Plug in the electrical cord and look in the sight hole in the back of the motor to see that it is running. Set the days that regeneration is to occur by sliding tabs on skipper wheel upward .
  - Each tab is one day.
  - Finger at red pointer is tonight.
  - Moving clockwise from red pointer, pull or push fingers to obtain the desired regeneration schedule.
9. Set time of day by pushing blue button and spin the 24-hour gear until the present time of day is visible above the time of day arrow

**Filter Timer Regeneration Reference Chart**

Sand Filter	Sediment Turbidity	Mild				Average				Extreme							
		0.5	1	1.5	2	2.5	3	3.5	4	4.5	5	5.5	6	6.5	7	7.5	8
Activated Carbon Filters	Taste Odor	Mild				Average				Extreme							
Iron Filters	PPM IronX1 PPM ManganeseX1 PPM SulphurX1	0.5	1	1.5	2	2.5	3	3.5	4	4.5	5	5.5	6	6.5	7	7.5	8
No. Of Persons		Calendar Clock Regenerations Frequency - No. Of Tab Pull Upwards															
2	1	1	1	1	1	2	2	2	2	2	3	3	3	3	3	3	3
3	1	1	2	2	3	3	3	3	3	3	4	4	4	4	4	4	4
4	1	2	2	2	3	3	3	4	4	4	4	6	6	6	6	6	6
5	2	2	3	3	4	4	4	4	6	6	6	6	6	12	12	12	12
6	2	2	3	3	4	4	4	6	6	6	6	6	6	12	12	12	12
7	2	3	3	4	4	6	6	6	6	12	12	12	12	12	12	12	12
8	2	3	3	4	6	6	6	6	6	12	12	12	12	12	12	12	12
9	3	3	4	4	6	6	6	6	12	12	12	12	12	12	12	12	12
10	3	4	4	6	6	12	12	12	12	12	12	12	12	12	12	12	12

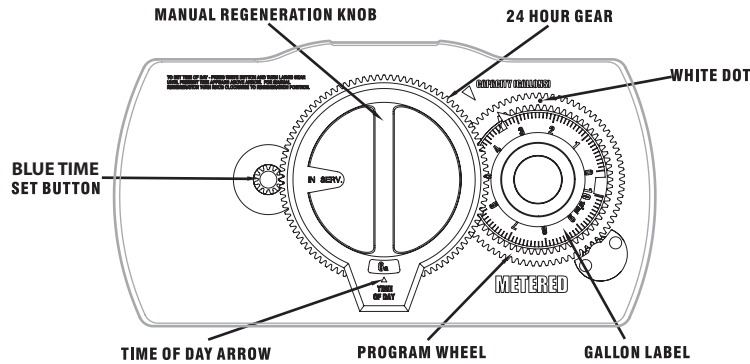

**Model: AQT-56SM**

1. Manually index the softener control to the In Service position and let water flow into the resin tank. When the water flow stops, open a softened water tap until all air is released from the lines. Then close tap.  
Note: The various regeneration positions may be dialed manually by turning the knob on the front of the control until the indicator shows that the softener is in the desired position.
2. Set water usage program wheel :Calculate the gallon capacity of the system by dividing the system capacity by the raw water hardness. Next subtract the necessary reserve requirement by multiplying the number of people in the house by 75 gallons (1 US gallon=3.785 L) per day. Set the gallons available at the small white dot on program wheel gear. The capacity arrow denotes remaining gallons exclusive of fixed reserve. The table below is also a quick reference to determine the gallons used before each regeneration.
3. Rotate program wheel counterclockwise until it stops at Regeneration position.
4. Manually index the control to the Backwash position and allow water to flow at the drain for 3 or 4 minutes.
5. Remove back cover plate.
6. Make sure than the salt dosage is set as recommended by the manufacturer. Manually index the control to the Brine Fill position and allow the brine tank to fill to the top of the air check.
7. Manually index the control to the Brine Rinse position and allow the control to draw water from the brine tank until it stops.
8. Plug in the electrical cord and look in the sight hole in the back of the motor to see that it is running.
9. Manually advance the control to the beginning of the Brine Fill position and allow the control to return to the In Service position automatically.
10. Fill the brine tank with salt.

**Softener Meter Capacity Reference Chart (Gallons)**

Capacity 18,000		Hardness PPM (GPG)						
		85(5)	171(10)	256(15)	342(20)	513(30)	684(40)	855(50)
No. Of Persons	1	2,100	1,725	1,125	825	525	375	285
	2	2,100	1,650	1,050	750	450	300	210
	3	2,100	1,575	975	675	375	225	135
	4	2,100	1,500	900	600	300	150	60
	5	2,100	1,425	825	525	225	75	0
	6	2,100	1,350	750	450	150	0	0

Capacity 24,000		Hardness PPM (GPG)						
		85(5)	171(10)	256(15)	342(20)	513(30)	684(40)	855(50)
No. Of Persons	1	2,100	2,100	1,525	1,125	725	525	405
	2	2,100	2,100	1,450	1,050	650	450	330
	3	2,100	2,100	1,375	975	575	375	255
	4	2,100	2,100	1,300	900	500	300	180
	5	2,100	2,025	1,225	825	425	225	105
	6	2,100	1,950	1,150	750	350	150	30

Capacity 30,000		Hardness PPM (GPG)						
		85(5)	171(10)	256(15)	342(20)	513(30)	684(40)	855(50)
No. Of Persons	1	2,100	2,100	1,925	1,425	925	675	525
	2	2,100	2,100	1,850	1,350	850	600	450
	3	2,100	2,100	1,775	1,275	775	525	375
	4	2,100	2,100	1,700	1,200	700	450	300
	5	2,100	2,100	1,625	1,125	625	375	225
	6	2,100	2,100	1,550	1,050	550	300	150

Capacity 36,000		Hardness PPM (GPG)						
		85(5)	171(10)	256(15)	342(20)	513(30)	684(40)	855(50)
No. Of Persons	1	2,100	2,100	2,100	1,725	1,125	825	645
	2	2,100	2,100	2,100	1,650	1,050	750	570
	3	2,100	2,100	2,100	1,575	975	675	495
	4	2,100	2,100	2,100	1,500	900	600	420
	5	2,100	2,100	2,025	1,425	825	525	345
	6	2,100	2,100	1,950	1,350	750	450	270

**Softener Meter Capacity Reference Chart (Liters)**

Capacity 18,000								
No. Of Persons	1	555	456	297	218	139	99	75
	2	555	436	277	198	119	79	55
	3	555	416	258	178	99	59	36
	4	555	396	238	159	79	40	16
	5	555	376	218	139	59	20	0
	6	555	357	198	119	40	0	0

Capacity 24,000								
No. Of Persons	1	555	555	403	297	192	139	107
	2	555	555	383	277	172	119	87
	3	555	555	363	258	152	99	67
	4	555	555	343	238	132	79	48
	5	555	535	324	218	112	59	28
	6	555	515	304	198	92	40	8

Capacity 30,000								
No. Of Persons	1	555	555	509	376	244	178	139
	2	555	555	489	357	225	159	119
	3	555	555	469	337	205	139	99
	4	555	555	449	317	185	119	79
	5	555	555	429	297	165	99	59
	6	555	555	410	277	145	79	40

Capacity 36,000								
No. Of Persons	1	555	555	555	456	297	218	170
	2	555	555	555	436	277	198	151
	3	555	555	555	416	258	178	131
	4	555	555	555	396	238	159	111
	5	555	555	535	376	218	139	91
	6	555	555	515	357	198	119	71

# Water Conditioner

## Flow Diagrams

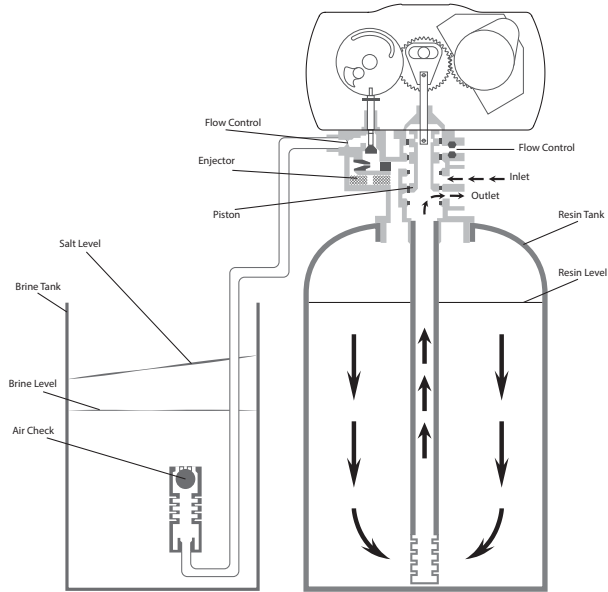

### 1) Service Position

Hard water enters unit at valve inlet and flows down through the mineral in the mineral tank. Conditioned water enters center tube through the bottom distributor, then flows up through the center tube, around the piston, and out the outlet of the valve.

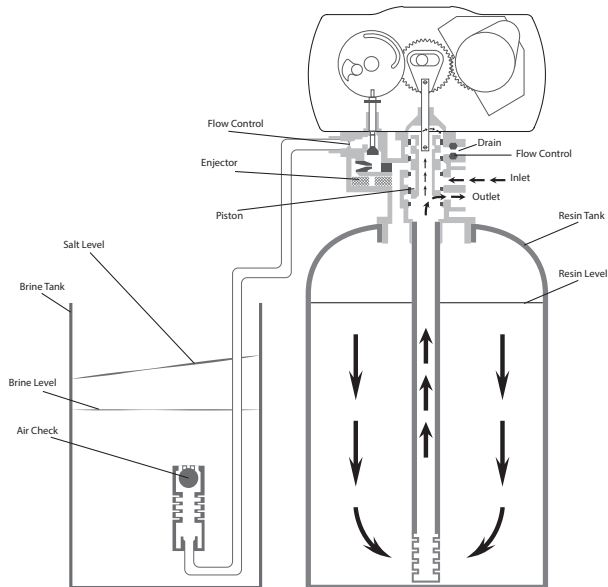

### 2) Preliminary Rinse Position

Slow rinse of the resin bed. Water flows down through the resin bed, up the bottom distributor and out the drain.



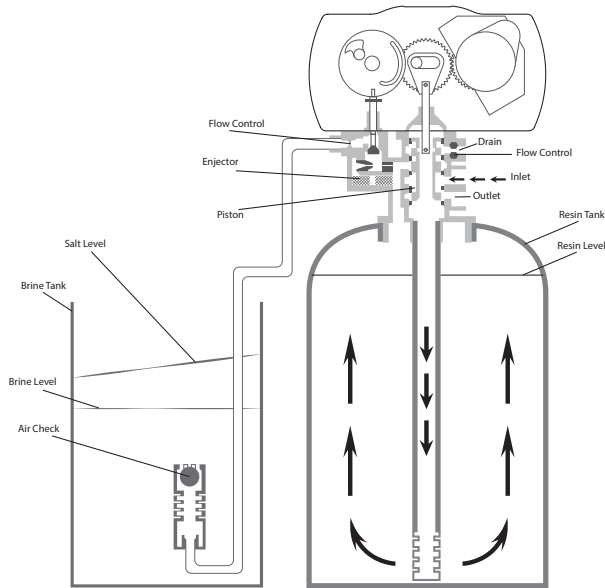

**3) Backwash Position**

Hard water enters unit at valve inlet, flows through piston, down center tube, through bottom distributor, up the through the mineral, around the piston and out the drain line. Water is passed through the resin bed in the opposite direction of normal flow, which flushes suspended matter out of the resin tank. Backwashing also loosens the resin bed which becomes compacted during the softening (in service) cycle.

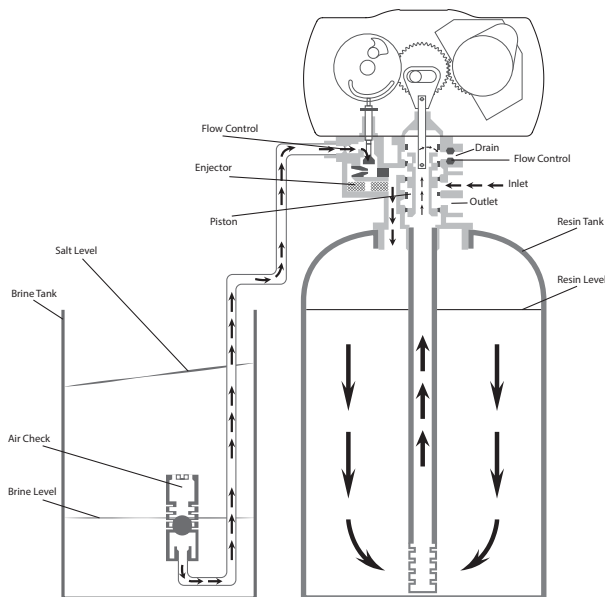

**4) Brine Position (Softeners Only)**

Hard water enters unit at valve inlet, flows up into injector housing and down through nozzle and throat to draw brine from the brine tank, brine flows down through mineral and enters the center tube through the bottom distributor and out through the drain line. The resin beads are washed with the strong solution of salt water which is called the brine solution. Since the resin beads prefer calcium and magnesium ions.

# Water Conditioner

## Flow Diagrams

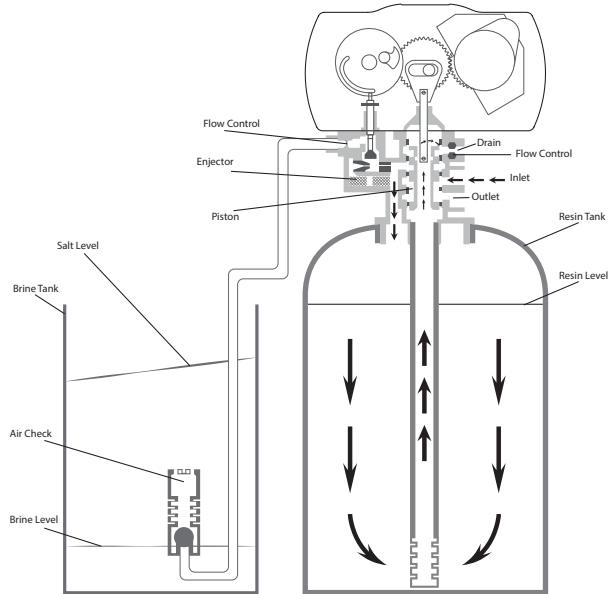

### 5) Slow Rinse Position (Softeners Only)

After all the brine has been drawn from the brine tank, hard water continues to enter through the valve inlet, flows around the lower piston groove and through the nozzle and throat, down through the resin and into the distributor, then up through the center tube, at last through the center hole in the piston and out the drain.

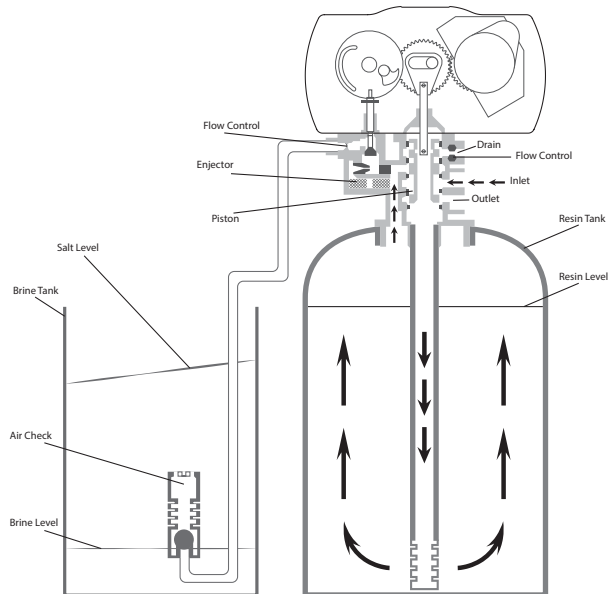

### 6) Rapid Rinse Position (Second Backwash Position)

The resin bed rinsed to remove excess brine solution from the tank and the resin beads are ready to produce soft water again. Hard water enters unit at valve inlet, flows through piston, down center tube, through bottom distributor, and up through the mineral, around the piston and out the drain line.

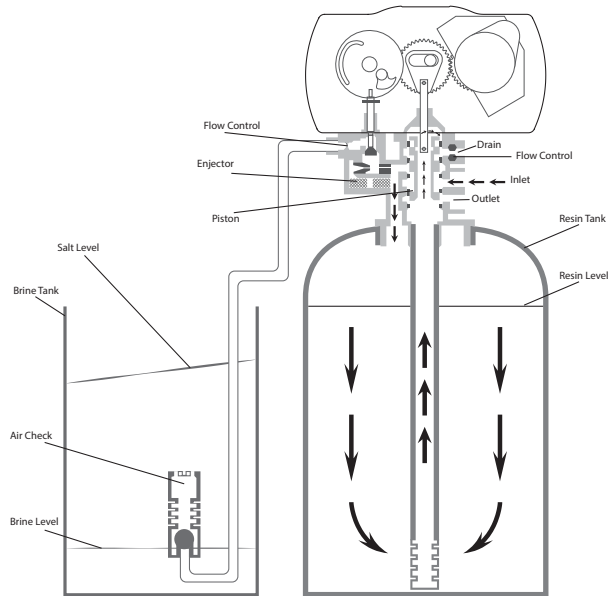

**7) Settling Rinse Position**

Slow rinse of the resin bed. Water flows down through the resin bed up the bottom distributor and out the drain.

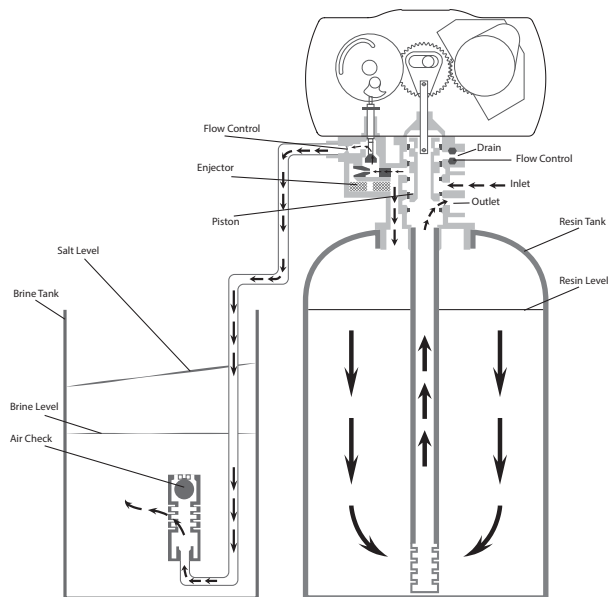

**8) Brine Tank Fill Position (Softeners Only)**

Hard water enters unit at valve inlet, flows up through the injector housing, through the brine valve to refill the brine tank. Valve is now delivering soft water to the home. Raw water is refilling the brine tank to make brine solution for the next regeneration.

**Note: Regeneration**

When the valve is in regeneration, raw water is being passed to service until rapid rinse is complete.

# AQT-56ST Time Control

Valve Drive Assembly

## AQT-56ST Time Control Valve Drive Assembly

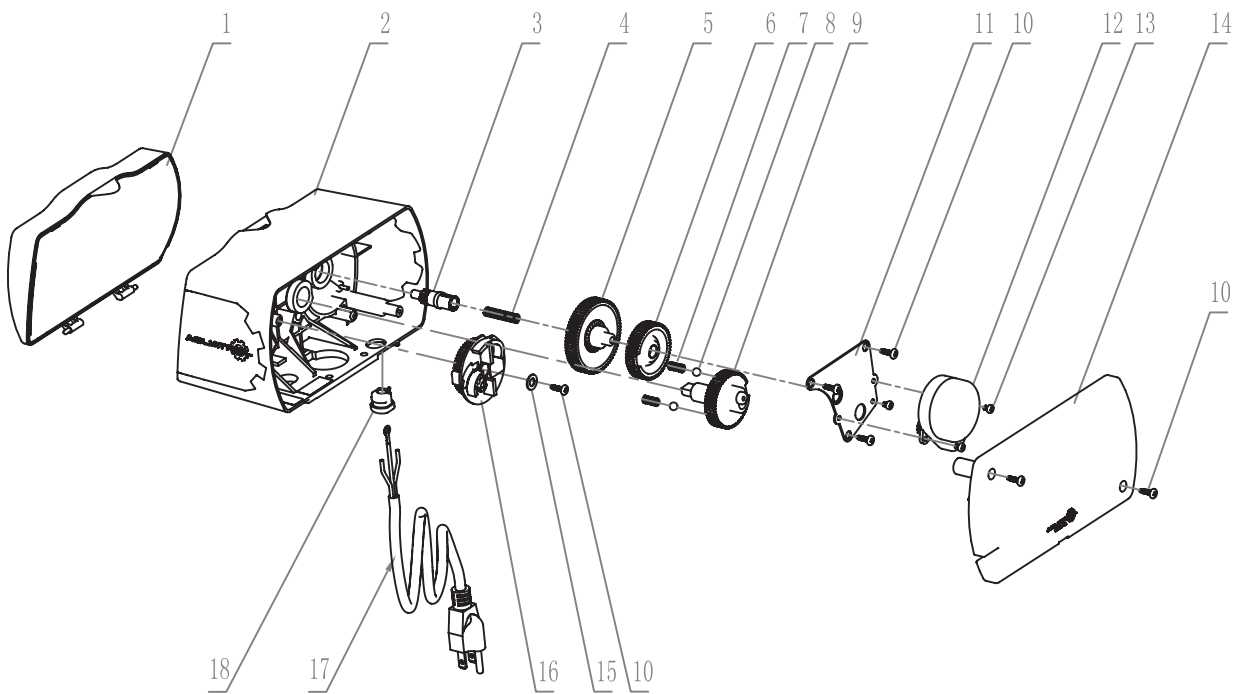
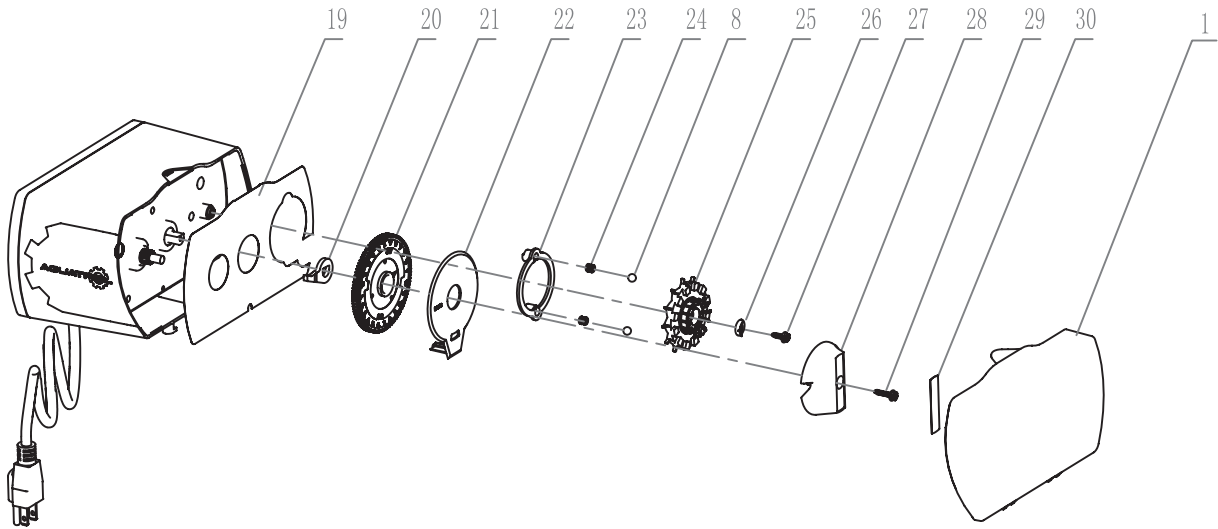

## Time Control

### Valve Drive Assembly Parts List

Item No.	Quantity	Part No.	Description
1	1	A-15613	Front Cover
2	1	A-S0001	Housing Assembly
3	1	A-13018	Idler Pointer
4	1	A-13312	Spring Idler
5	1	A-13017	Idler Gear
6	1	A-13164	Drive Gear
7	2	A-14457	Spring, Detent, Main Gear
8	4	A-13300	Ball
9	1	A-13170	Main Gear and Shaft
10	6	A-13296	Screw
11	1	A-15650	Motor Mounting Plate
* 12	1		Motor
13	3	A-11384	Screw, Motor mtg. and Ground wire
14	1	A-15614	Back Cover
15	1	A-12037	Washer
16	1	A-60514-01	Brine Cam Assembly, 7-30 lbs
	1	A-66114	Brine Cam Assembly, 4-6 kg
	1	A-60514	Brine Cam Assembly, 3.5-15 lbs
* 17	1		Electrical Cord
18	1	A-13547	Strain Relief
19	1	A-15678	Front Label
20	1	A-13011	Cycle Actuator Gear
21	1	A-19205	24-hour Gear Assembly, Silver
22	1	A-16715	Vale Position Dial, Filter
	1	A-14176	Vale Position Dial, Standard
23	1	A-13864	Skipper Wheel Ring
24	2	A-13311	Spring, Detent, Skipper Wheel
25	1	A-14381	Skipper Wheel Assembly, 12-Day
26	1	A-13014	Regeneration Pointer
27	1	A-02107	Screw, Skipper Wheel Assembly
28	1	A-14177	Knob, Manual Regeneration
29	1	A-15151	Screw
30	1	A-15677	Knob Label

\* For more options please refer to Page 3

# AQT-56SM Meter Control

Valve Drive Assembly

## AQT-56SM Meter Control Valve Drive Assembly

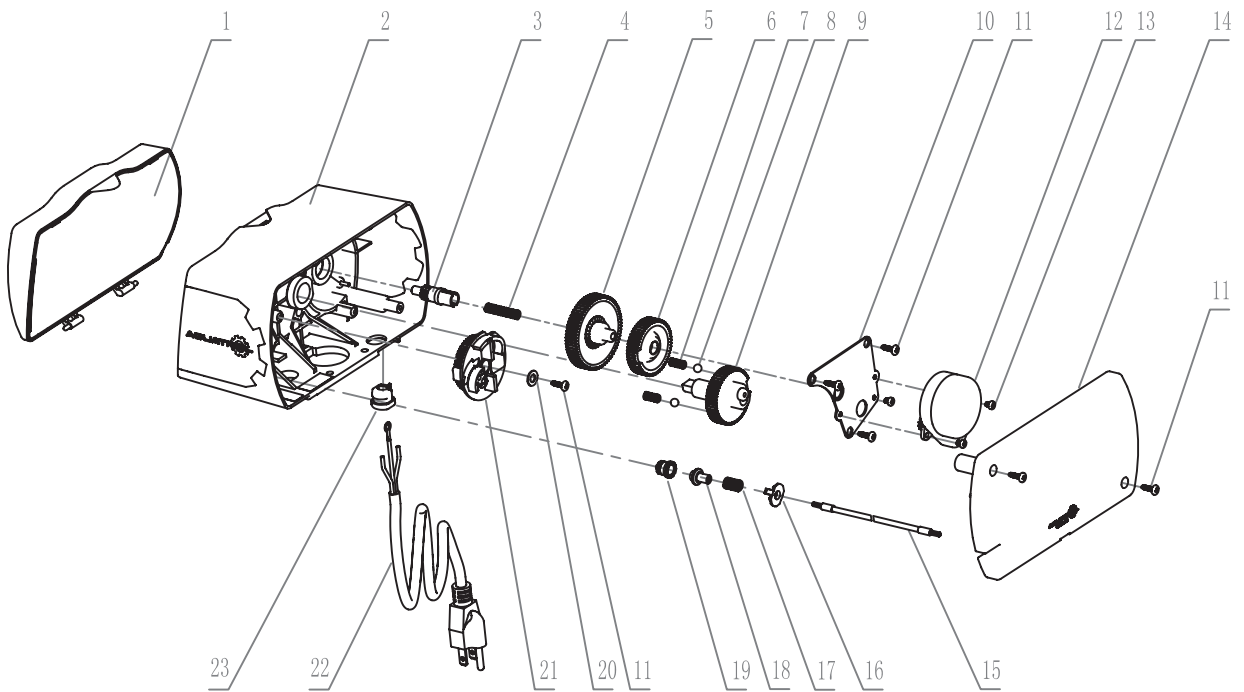
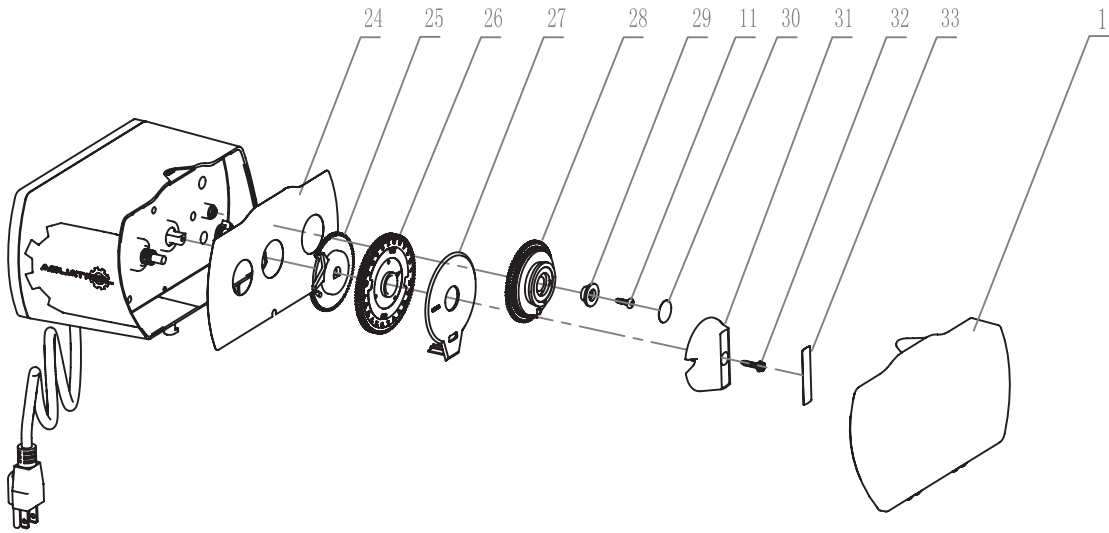

## Meter Control

### Valve Drive Assembly Parts List

Item No.	Quantity	Part No.	Description
1	1	A-15613	Front Cover
2	1	A-S0001	Housing Assembly
3	1	A-13018	Idler Pointer
4	1	A-13312	Spring Idler
5	1	A-13017	Idler Gear
6	1	A-13164	Drive Gear
7	2	A-14457	Spring, Detent, Main Gear
8	2	A-13300	Ball
9	1	A-13170	Main Gear and Shaft
10	1	A-15650	Motor Mounting Plate
11	7	A-13296	Screw
* 12	1		Motor
13	3	A-11384	Screw, Motor mtg. and Ground Wire
14	1	A-15614	Back Cover
15	1	A-14043	Cable Assembly
16	1	A-14253	Spring Retainer
17	1	A-14276	Spring
18	1	A-13831	Clutch, Drive Pinion
19	1	A-56206	Drive Pinion, Program Wheel
20	1	A-12037	Washer
21	1	A-60514-01	Brine Cam Assembly, 7-30lbs
	1	A-66114	Brine Cam Assembly, 4-6kg
	1	A-60514	Brine Cam Assembly, 3.5-15lbs
* 22	1		Electrical Cord
23	1	A-13547	Strain Relief
24	1	A-15679	Front Label
25	1	A-13802	Cycle Actuator Gear
26	1	A-19205	24-hour Gear Assembly, Silver
27	1	A-15478	Valve Position Dial, Filter
	1	A-14176	Valve Position Dial, Standard
28	1	A-A0007	Program Skipper Wheel Assembly, 10600gal
	1	A-A0006	Program Skipper Wheel Assembly, 2100gal
29	1	A-13806	Program Wheel Retainer
30	1	A-13953	Cover Label
31	1	A-14177	Knob, Manual Regeneration
32	1	A-15151	Screw, Knob
33	1	A-15677	Knob Label

\* For more options please refer to Page 3

# Control Valve

Assembly

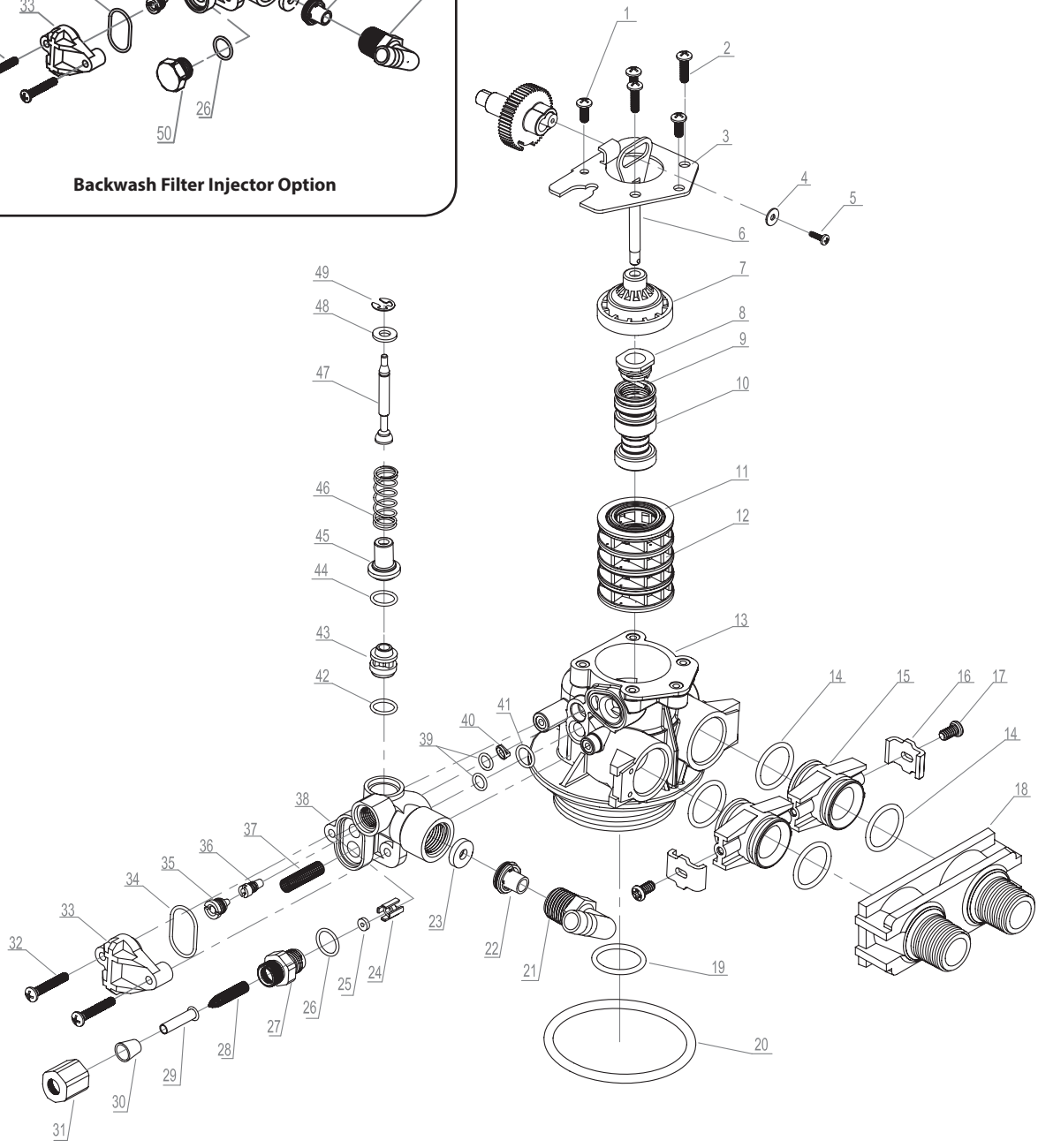
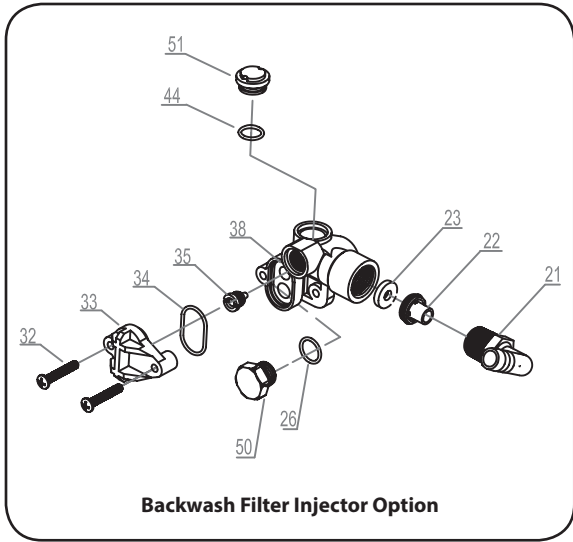



## Control Valve

Assembly Parts List

Item No.	Quantity	Part No.	Description
1	3	A-02001	Screw
2	2	A-02002	Screw-Drive Retainer
3	1	A-13546	End Plug Retainer
4	1	A-13363	Washer
5	1	A-13296	Screw
6	1	A-13001	Piston Rod Assembly
7	1	A-13446	End Plug Assembly
8	1	A-12953	Piston Retainer
9	1	A-10696	Piston Pin
10	1	A-13852	Piston, Filter
	1	A-13247	Piston, Softener
11	5	A-13242	Seal
12	4	A-14241	Spacer
13	1	A-61400-12	Valve Body Assembly
14	4	A-13305	O-ring, Adapter Coupling
15	2	A-19228	Adapter Coupling
16	2	A-13255	Adapter Clip
17	2	A-13314	Screw, Adapter Coupling
* 18	1		Yoke, Plastic
19	1	A-13304	O-ring, Distributor Tube
20	1	A-12281	O-ring, Top of Tank
21	1	A-13308	Brine House Barb, Straight
	1	A-56011	Brine House Barb, 90 Elbow
22	1	A-13173	DLFC Button Retainer Assembly
* 23	1		DLFC Button
24	1	A-13245	BLFC Button Retainer
* 25	1		BLFC Button
26	1	A-12977	O-ring, BLFC
27	1	A-13244	BLFC Fitting
28	1	A-12767	Screen, Brine Line
29	1	A-10332	BLFC Tube Insert
30	1	A-10330	BLFC Ferrule
31	1	A-10329	BLFC Fitting Nut
32	2	A-13315	Screw Injector Mounting
33	1	A-13166	Injector Cover
34	1	A-13303	O-ring, Injector Cover
* 35	1		Injector Nozzle
* 36	1		Injector Throat
37	1	A-10227	Screen, Injector
38	1	A-13163	Injector Body
39	2	A-13301	O-ring Injector
40	1	A-13497	Air Disperser
41	1	A-12638	O-ring, Drain
42	1	A-13302	O-ring
43	1	A-13167	Brine Valve Spacer
44	1	A-01003	O-ring, Brine Valve
45	1	A-13165/A-12550	Brine Valve Cap Assembly
46	1	A-11973	Spring, Brine Valve
47	1	A-13172/A-12626	Brine Piston Assembly
48	1	A-16098	Washer, Brine Valve
49	1	A-11981-01	Retaining Ring
50	1	A-13918	BLFC, Plug
51	1	A-13857	Brine Valve, Plug

\* For more options please refer to Page 3

# Meter Assembly

And Parts List

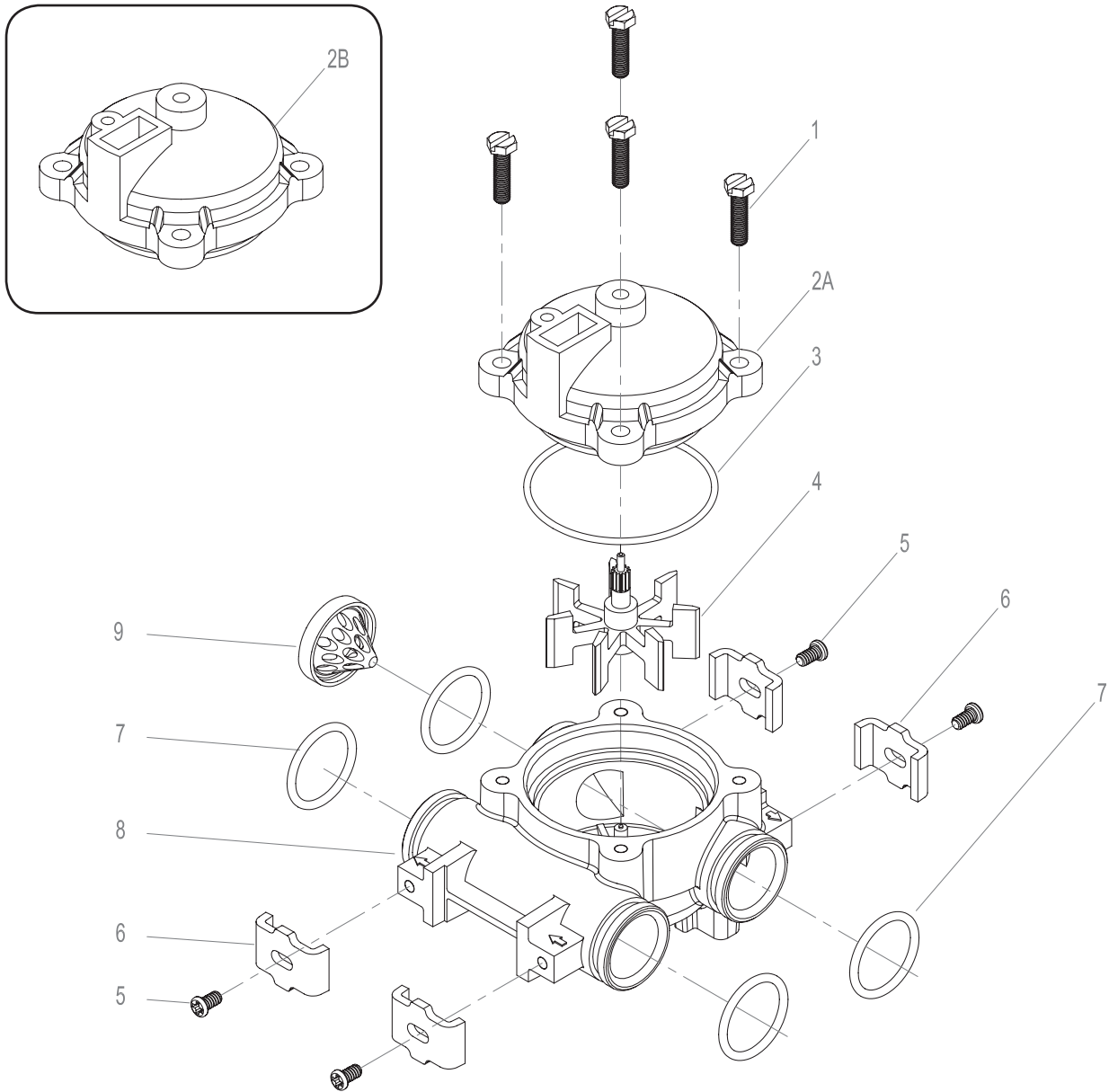

Item No.	Quantity	Part No.	Description
1	4	A-02082	Screw
2A	1	A-66120A	Meter Cover Assembly, 10600gal
2B	1	A-66120B	Meter Cover Assembly, 2100gal
3	1	A-13847	O-ring, Meter Cover Assembly
4	1	A-12204A	Impeller
5	4	A-13314	Screw, Adapter Clip
6	4	A-13255	Adapter Clip
7	4	A-13305	O-ring, Meter Body
8	1	A-12201	Meter Body
9	1	A-14613	Flow Straightener



